



Architectural Testing

**GUARDRAIL SYSTEM PERFORMANCE  
TEST REPORT**

**Rendered to:**

**CUSTOM DECORATIVE MOULDING  
PRODUCT: *Classic* 10 ft. PVC Guardrail System**

**Report No: 01-45123.01  
Report Date: 11/07/03**

130 Derry Court  
York, PA 17402-9405  
phone: 717.764.7700  
fax: 717.764.4129  
[www.archtest.com](http://www.archtest.com)



## GUARDRAIL SYSTEM PERFORMANCE TEST REPORT

Rendered to:

CUSTOM DECORATIVE MOULDING  
12136 Sussex Highway  
Greenwood, Delaware 19950

Report No.: 01-45123.01  
Test Date: 04/25/03  
Report Date: 11/07/03

**Product:** *Classic* 10 ft. PVC Guardrail System

**Project Summary:** Architectural Testing, Inc. (ATI) was contracted by Custom Decorative Moulding to conduct structural performance tests on their *Classic* PVC guardrail system. The system was evaluated for the design load requirements of the following building codes and standards:

IBC-2000 / ICC - *International Code Council*

BOCA-1999 - *Building Officials and Code Administrators* (Reference ASCE 7-95)

SBC-1999 / SBCCI - *Southern Building Code Conference International*

All tests performed are to evaluate structural performance of the railing assembly to carry and transfer imposed loads to the supports (posts). The test specimen evaluated includes the pickets, rails, rail brackets and attachment to the post. The support posts are not a tested component and are included in the test specimen only to facilitate anchorage of the rail brackets.

**Test Specimen (Railing Assembly) Description:** The railing consisted of a top and bottom rail reinforced with P-Channel with an overall length of 119-5/8". The top rail also utilized a 1" diameter EMT conduit, which ran the entire length of the rail, for additional reinforcement. The railing measured 40" high overall bottom rail to top rail. Spaced, notched pickets which inserted into cutouts in the top and bottom rails provided a 3-5/8" clearance between pickets. The rails are attached to an aluminum post, supplied by Custom Decorative Moulding, with molded PVC brackets. The brackets incorporated a stainless steel plate which was positioned on the inside mounting location of the bracket. The brackets were then attached to the aluminum post with a PVC retainer clip. Two (2) #8 x 3/4" stainless steel screws were placed on both sides of the top rail brackets for attachment to the rail. One (1) #8 x 3/4" stainless steel screw was placed on the under side of the bottom rail brackets for attachment to the rail. See drawings and photographs in Appendices A and B for additional detail.

130 Derry Court  
York, PA 17402-9405  
phone: 717.764.7700  
fax: 717.764.4129  
www.archtest.com

**Equipment:** Railing assemblies were tested in a self-contained structural frame designed to accommodate anchorage of the rail assembly and application of the required test loads. The specimen was loaded using an electric winch mounted to a rigid steel test frame. High strength cables, nylon lifting straps and load distribution beams were used to impose test loads on the specimen. Applied load was measured using an electronic load cell located in-line within the loading system. Deflections were measured to the nearest 0.01" using electronic linear transducers.

**Set-Up:** All railing assemblies were installed and tested as a single railing section by directly securing the posts into a rigid steel test frame. The test fixture rigidly restrained the posts from deflecting. Transducers mounted to an independent reference frame were located to record movement of reference points on the railing system components (ends and mid-point) to determine net component deflections. Uniform distributed loads with simple end supports were simulated with 1/4-point loading. See photographs for individual test setups.

**Test Procedure:** The test specimen is inspected prior to testing to verify size and general condition of the materials, assembly and installation. Any potentially compromising defects observed are noted prior to the load test. The assembly is preloaded up to a level not exceeding design load. After pre-loading, all load is released and any necessary fixture adjustments are made. An initial load, not exceeding 20% of design load, is applied and initial deflections recorded or transducers zeroed. Loads are then applied at a steady uniform rate stopping at 20% design load increments to record deflections. The load/deflection procedure continues until reaching 2.0 times design load within a time period of 5-10 minutes. At 2.0 times design load, the load is released. After allowing a minimum period of one minute for stabilization, load is reapplied to the initial load used at the start of the load/deflection procedure and deflections are recorded and used to analyze recovery. For tests that require ultimate loads greater than 2.0 times design load, loading is reapplied and increased at a steady uniform rate until failure occurs or the required ultimate load is reached. The testing time is continually recorded from the application of initial test load until the maximum test load is reached.

**Test Results:** The following tests were performed on the rail assemblies for the design load requirements of each code as referenced. Rail and picket test results are mid-point deflections for the given test load. Deflection and permanent set are component deflections relative to their end-points. They are not overall system displacement. All loads are horizontal except the SBC top rail design load (see results). All displacement measurements are horizontal. Deflection analysis uses linear regression through the linear range of the load/deflection data. The test results apply only to the components tested, which include the top rail, bottom rail, rail brackets and pickets. Posts are not a tested component and are included in the test setup only to facilitate the rail bracket anchorage.

## Test Results: (Continued)

## Test #1 - 04/25/03

Design Load: 50# / 1 sq. ft. In-Fill @ Center (Three Pickets) <sup>1</sup>

Load Level <sup>2</sup>	Test Load (lbs)	Test Data - Deflection (inches)				Deflection Analysis	
		Top-1	Mid	Bot-2	Net	y = mx	Deflection
0.0	0	-	-	-	-	0.00	0.00
0.6	30	0.00	0.00	0.00	0.00	0.16	0.21
0.8	40	0.06	0.08	0.06	0.02	0.21	0.23
1.0	52	0.13	0.20	0.13	0.07	0.27	0.28
1.2	60	0.18	0.28	0.18	0.10	0.31	0.31
1.4	70	0.26	0.42	0.27	0.16	0.37	0.36
1.6	81	0.34	0.57	0.35	0.22	0.42	0.42
1.8	91	0.43	0.71	0.45	0.27	0.48	0.48
2.0	100	0.50	0.83	0.52	0.32	0.52	0.52
0.1	30	-0.08	-0.12	-0.07	-0.05	100% Recovery	
2.5	130	Maximum Test Load - Sustained without failure.					

<sup>1</sup> Test conducted w.o./ 1" diameter EMT in top rail<sup>2</sup> Load level represents % of design load.

## Test #2 - 04/25/03

Design Load: 200# / 1 sq. ft. In-Fill @ Center (Three Pickets) <sup>1</sup>

Load Level <sup>2</sup>	Test Load (lbs)	Test Data - Deflection (inches)				Deflection Analysis	
		Top-1	Mid	Bot-2	Net	y = mx	Deflection
0.0	0	-	-	-	-	0.00	0.00
0.1	30	0.00	0.00	0.00	0.00	0.14	0.14
0.2	40	0.06	0.08	0.06	0.02	0.18	0.17
0.4	80	0.34	0.57	0.35	0.22	0.37	0.36
0.6	120	0.61	1.02	0.65	0.40	0.55	0.54
0.8	160	0.96	1.58	1.01	0.60	0.73	0.74
1.0	201	1.27	2.10	1.35	0.79	0.92	0.93
1.2	243	1.60	2.62	1.70	0.97	1.11	1.12
1.4	282	1.93	3.13	2.05	1.14	1.29	1.29
1.6	320	2.24	3.60	2.35	1.31	1.46	1.45
1.8	368	2.57	4.13	2.69	1.50	1.68	1.64
2.0	402	2.84	4.55	2.97	1.65	1.84	1.79
0.1	30	-0.04	-0.03	0.00	-0.01	100% Recovery	
2.0	402	Maximum Test Load - Sustained without failure.					

<sup>1</sup> Test conducted w.o./ 1" diameter EMT in top rail<sup>2</sup> Load level represents % of design load.

Test Results: (Continued)

**Test #3 - Test Date: 04/25/03**  
**(50 Horizontal + 100 Vertical) plf Uniform Load<sup>1</sup> on Top Rail / SBC**

Load Level <sup>2</sup>	Test Load (lbs)	Test Data - Deflection (inches)				Deflection Analysis	
		End-1	Mid	End-2	Net	y = mx	Deflection
0.0	0	-	-	-	-	0.00	0.00
0.1	70	0.00	0.00	0.00	0.00	0.20	0.11
0.2	231	0.02	0.60	0.16	0.51	0.67	0.61
0.4	463	0.11	1.38	0.11	1.27	1.34	1.38
0.6	730	0.21	2.24	0.23	2.03	2.11	2.13
0.8	899	0.27	2.78	0.30	2.49	2.59	2.60
1.0	1132	0.37	3.53	0.40	3.15	3.27	3.26
1.2	1357	0.46	4.27	0.51	3.79	3.91	3.89
1.4	1592	0.59	5.29	0.66	4.67	4.59	4.77
1.6	1800	0.71	6.17	0.79	5.42	5.19	5.53
1.8	2029	0.85	7.27	0.94	6.37	5.85	6.48
2.0	2246	1.02	8.42	1.14	7.34	6.48	7.45
0.1	70	0.08	1.75	0.10	1.67	77% Recovery <sup>3</sup>	
2.0	2246	Maximum Test Load - Sustained without failure.					

<sup>1</sup> Tested with resultant load = 112 plf @ -63.4° from horizontal. Uniform load simulated with equivalent 1/4-point loads.

<sup>2</sup> Load level represents % of design load.

<sup>3</sup> After 24 min. of relaxation.

A copy of this report and all supporting data will be retained by ATI for a period of four years. This report is the exclusive property of the client so named herein and is applicable only to the sample tested. Results obtained are tested values and do not constitute an opinion or endorsement by this laboratory. This report may not be reproduced, except in full, without the written approval of Architectural Testing.

For ARCHITECTURAL TESTING, INC.

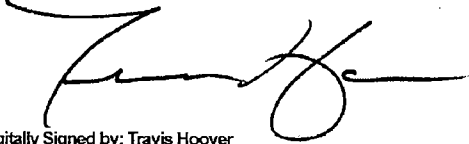

Digitally Signed by: Travis Hoover

---

Travis A. Hoover  
Project Engineer

TAH:tah/nlb  
01-45123.01

Attachments (pages)

- Appendix A: Drawings (6)
- Appendix B: Photographs (4)

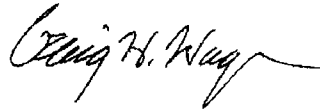

Digitally Signed by: Craig H. Wagner

---

Craig H. Wagner, P.E.  
Director - Code Compliance

11/10/03



**DOCUMENT CONTROL ADDENDUM #01-45123.00**

**Current Issue Date: 11/07/03**

---

**Report No.: 01-45123.01**

**Requested by:** Jeff Davis, Custom Decorative Moulding

**Purpose:** Structural performance testing of *Classic* 10 ft. PVC guardrail system.

**Issued Date:** 11/07/03

**Comments:** P.E. review and seal required.

## **APPENDIX A**

### **Drawings**





Test sample complies with these details.  
Deviations are noted.

Report# 01-4512301  
Date 6.5.03 Tech JTB

# Traditional 10" SECTION

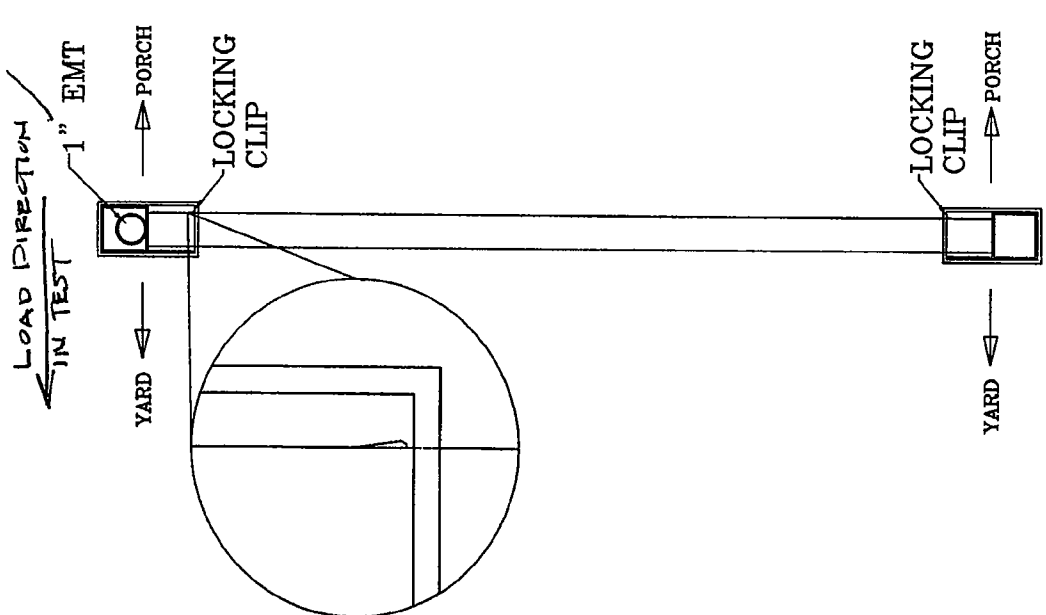
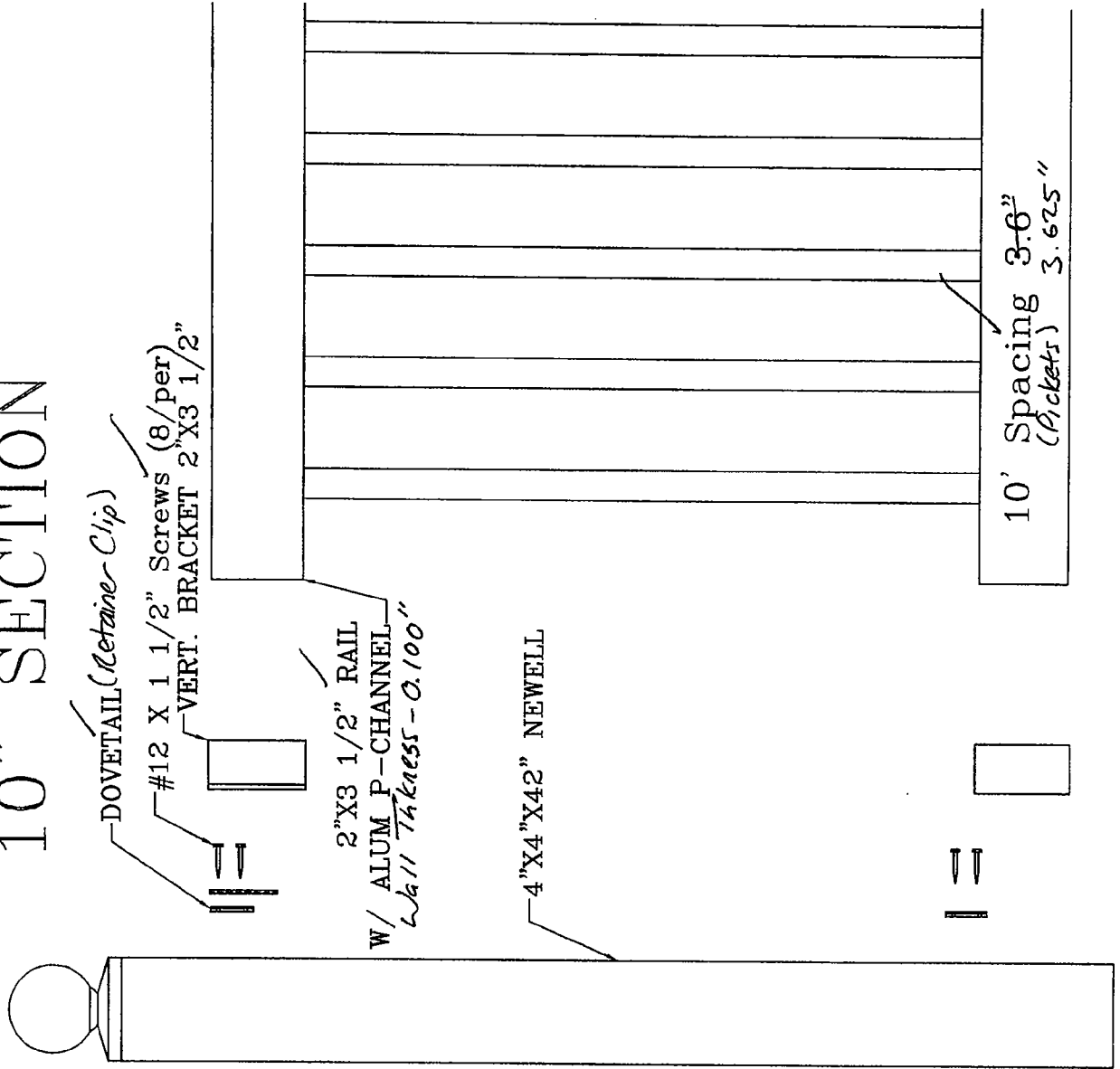

Test sample complies with these details.  
Deviations are noted.

Report# 01-4512301  
Date 6.5.03 Tech JTB

# Traditional 10" SECTION

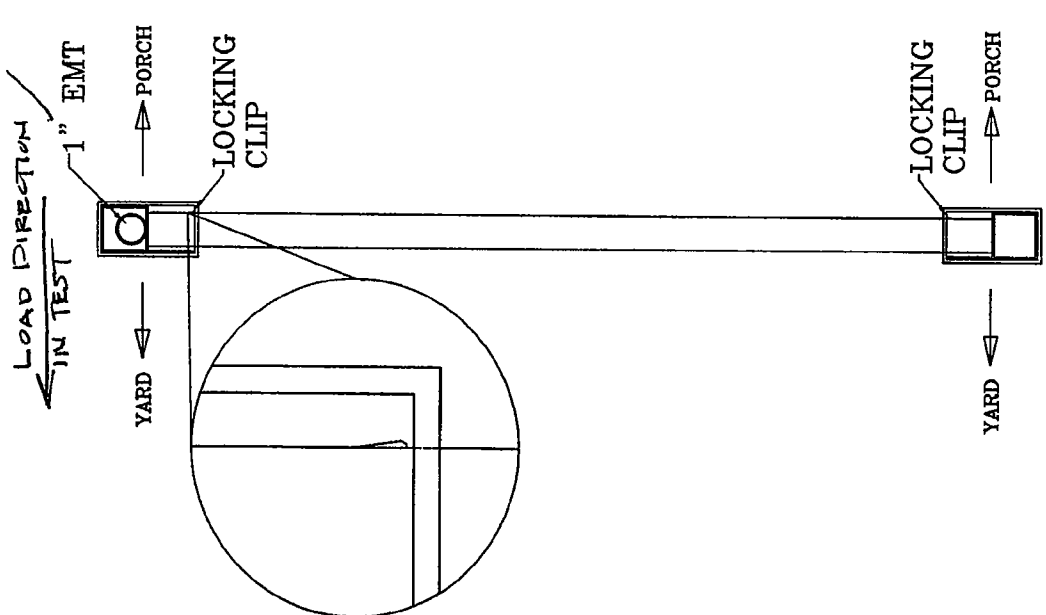
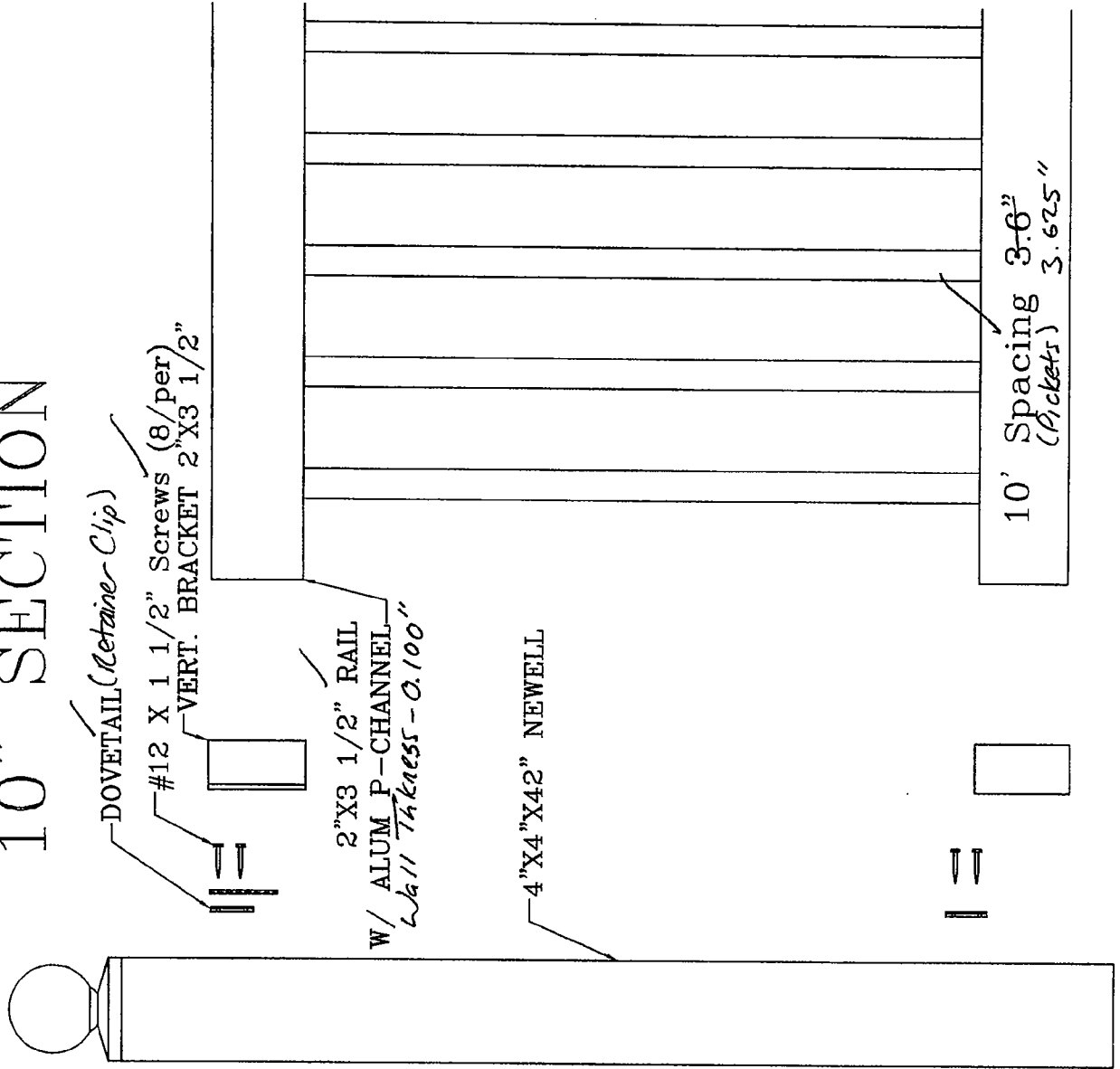

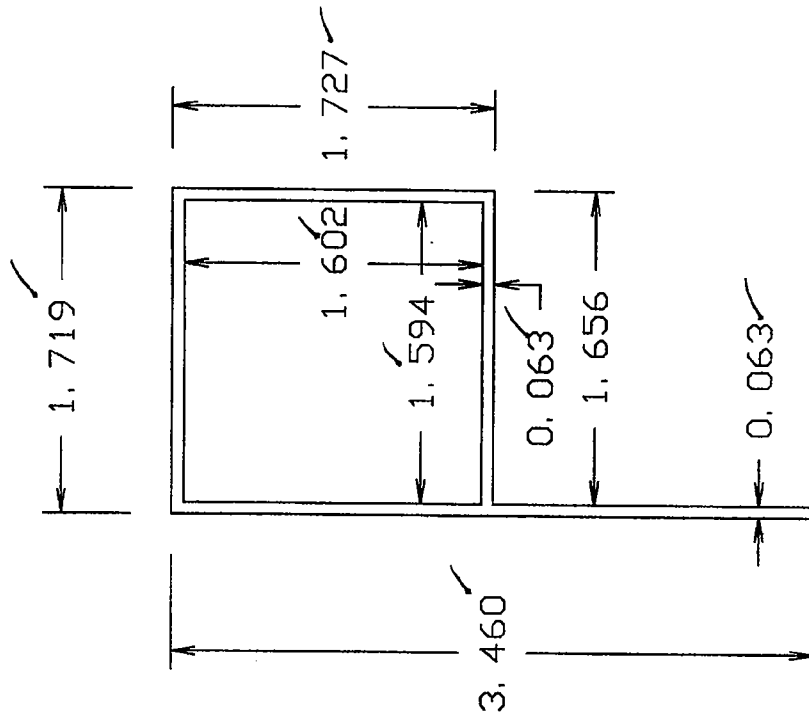

Architectural Testing

Test sample complies with these details.  
Deviations are noted.

Report# 01-45723-01  
Date 6-5-3 Tech MDW

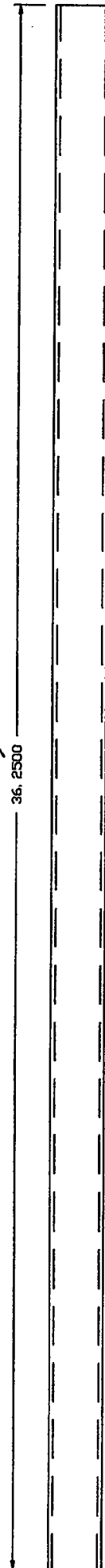
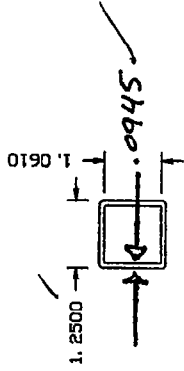

Architectural Testing

Test sample complies with these details.  
Deviations are noted.

Report# 01-45123-01  
Date 6.5.3 Tech Man

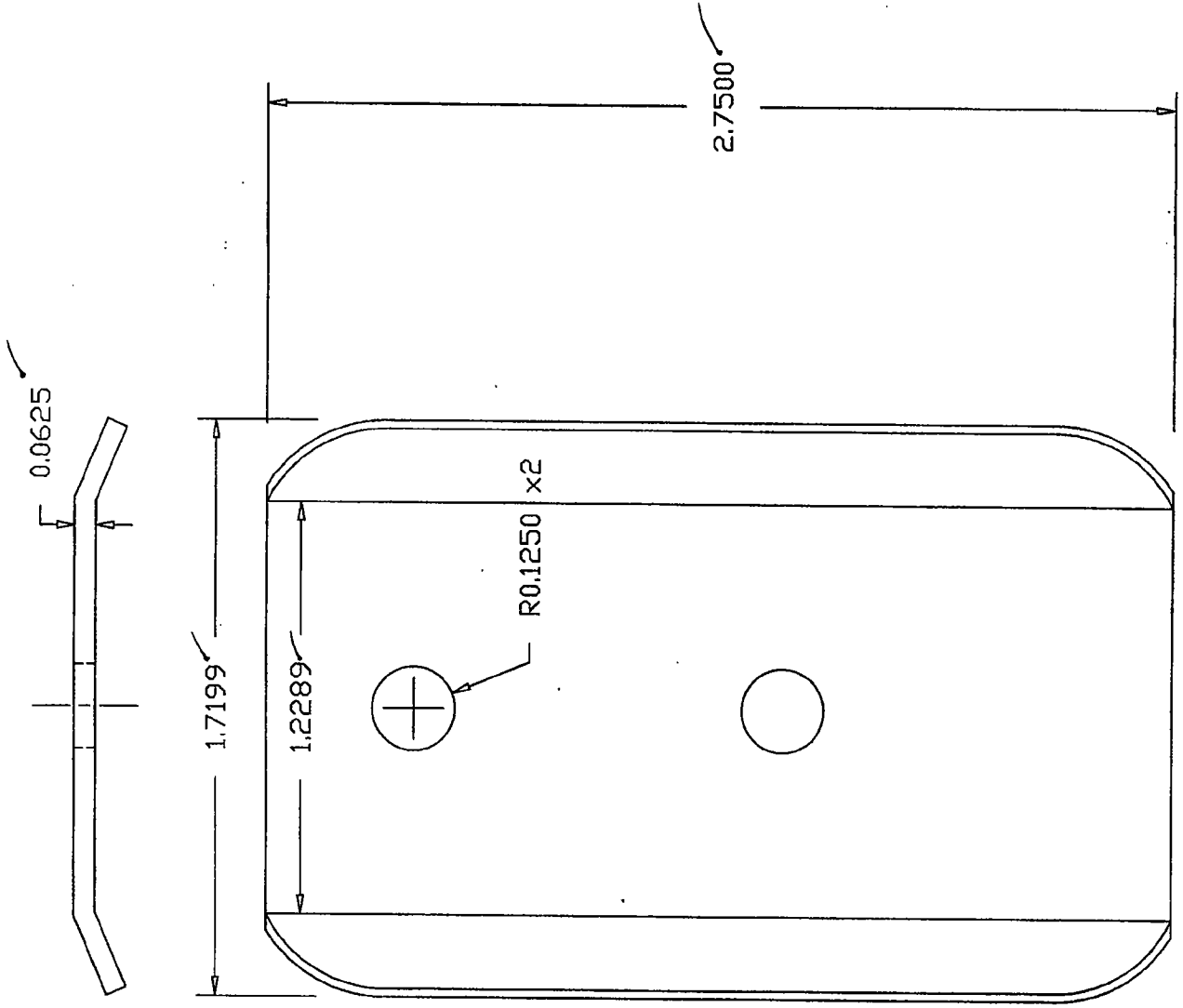

Architectural Testing

Test sample complies with these details.  
Deviations are noted.

Report# 01-45723.01  
Date 6-5-3 Tech JM.L

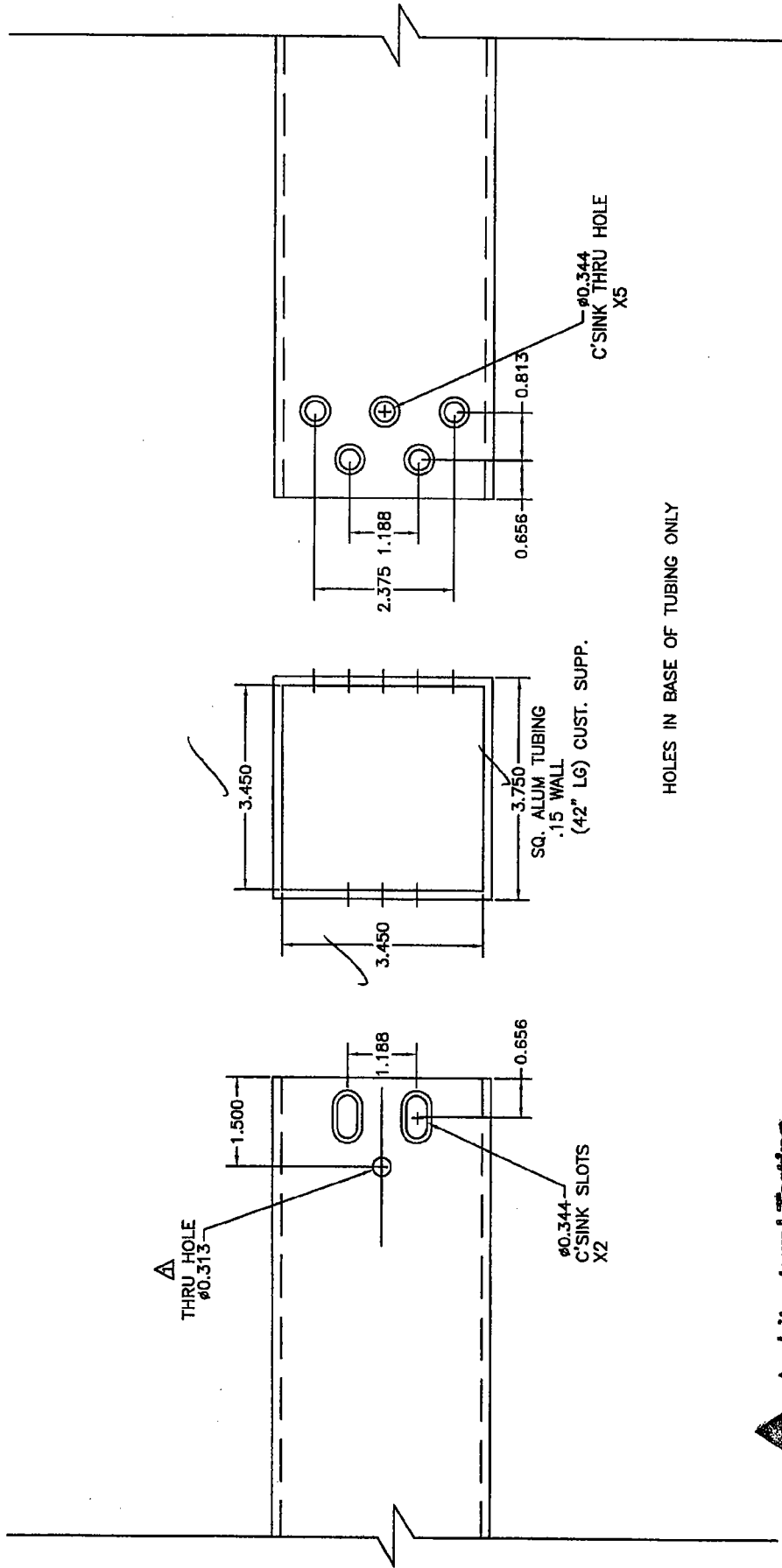

Test sample complies with these details.  
Deviations are noted.

Report# 01-45123.01  
Date 6.5.03 Tech 716

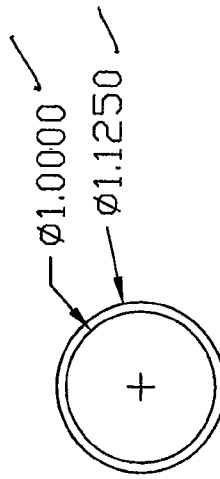

E.M.T. Conduit

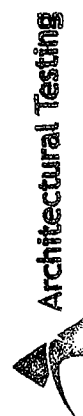

Architectural Testing

Test sample complies with these details.  
Deviations are noted.

Report# 01-45/23.01

Date 6.5.03 Tech 76

## **APPENDIX B**

### **Photographs**

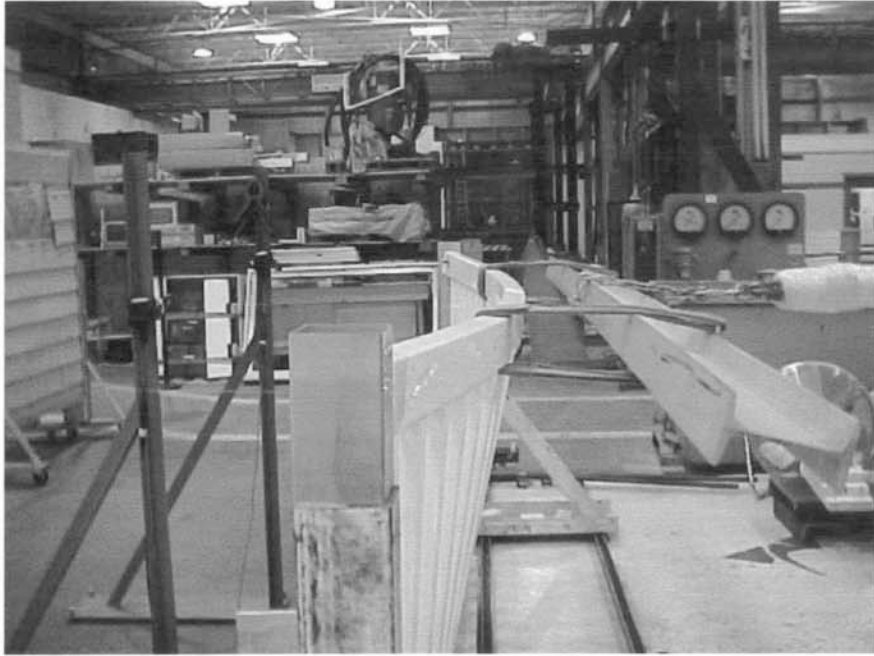

**Photo No. 1**  
**In-Fill Load Test**



**Photo No. 2**  
**SBC Top Rail Load Test**

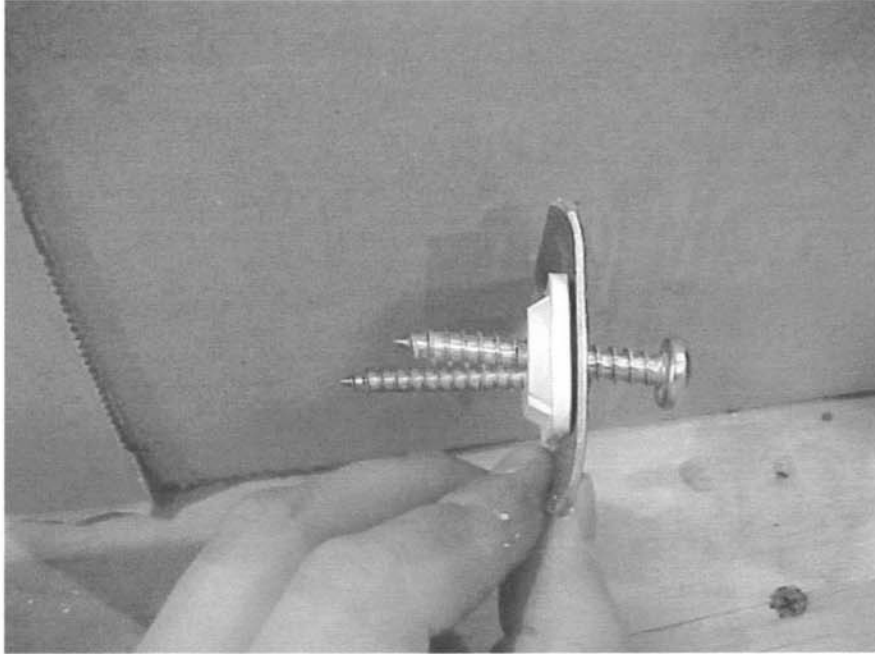



**Photo No. 3**  
**50 plf Top Rail Load Test**



**Photo No. 4**  
**Bracket with Stainless Steel Plate**



**Photo No. 5**  
**Stainless Steel Plate with PVC Retainer Clip**

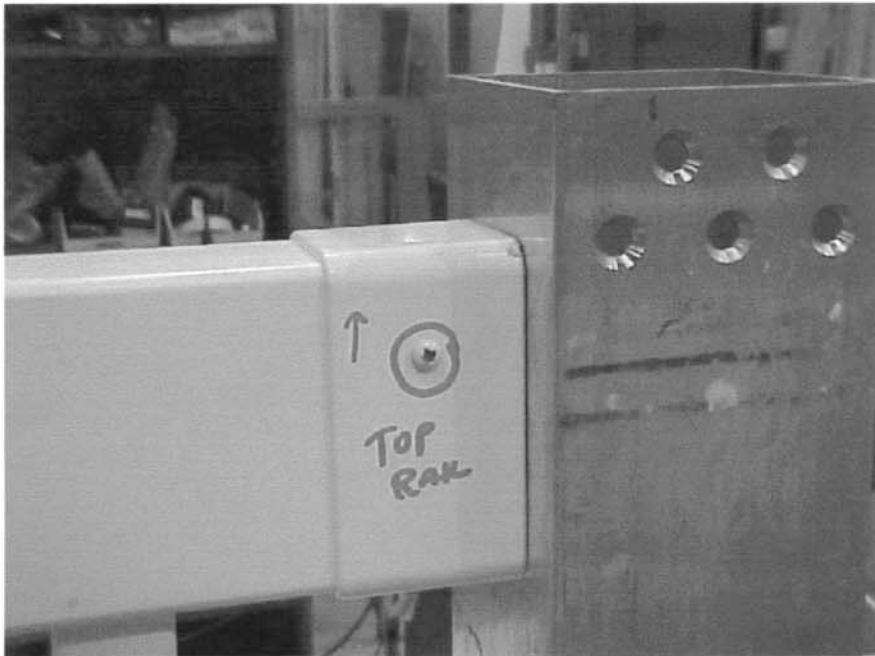

**Photo No. 6**  
**Top Rail Bracket**



**Photo No. 7**  
**Bottom Rail Bracket**